

AMP

***customer
manual***



AMP-O-MATIC* Side Feed Stripper-Crimper
Model II Machine No. 854040-1 and -2

Customer Manual

409-5807

26 AUG 94 Rev E

customer manual

Prepared by
Global Engineering and Manufacturing Standards
AMP Incorporated
P.O. Box 3608
Harrisburg, PA 17105-3608

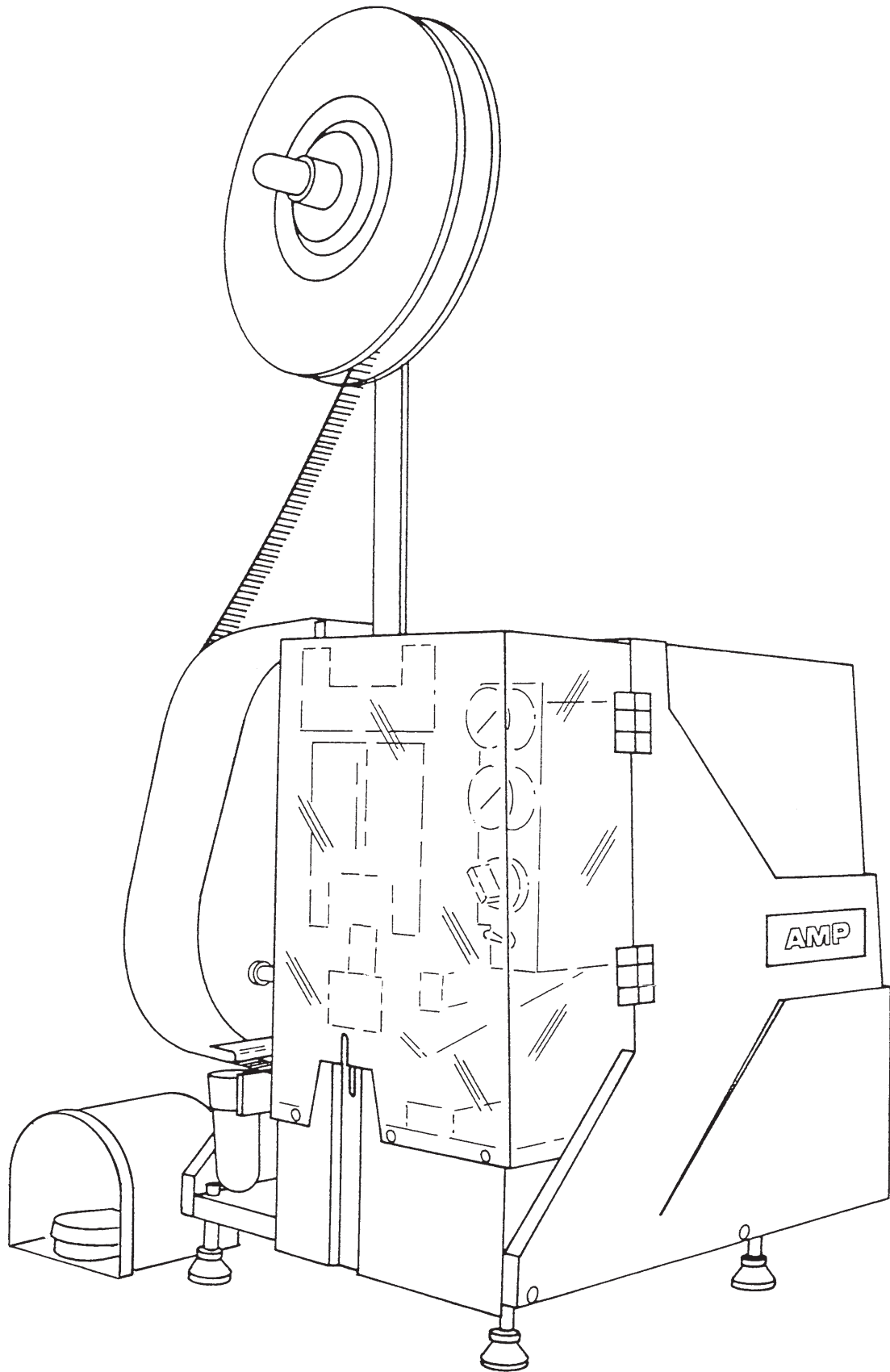

Frontispiece: AMP-O-MATIC Side Feed Stripper-Crimper Model II, 854040-1 and -2

DANGER**SAFETY PRECAUTIONS PREVENT INJURY**

Safeguards are designed into AMP machines to protect operating personnel from most hazards during normal machine operation. However, as with most machinery, certain precautions must be taken by the operator and repairman.

Never insert hands into an installed machine/applicator, or any part of a machine that is operated by electricity or compressed air, without first pulling the machine power cable plug from the outlet receptacle and/or shutting off the compressed air at the line valve and disconnecting the air hose. This will prevent injury in the event that switches or other controls are accidentally activated.

A grounded electrical outlet should always be used to receive the plug on the machine power cable.

To improve clarity, photographs and drawings may not show machine/applicator guards. In some cases, it is impractical to show the variety of guards designed to meet specific safety requirements, as set forth in codes and standards adopted by customers and/or enforced in a given locale.

Though a guard may not be shown, and procedures may not reflect the need for its removal, the guard **must** be in place during normal operation of the machine/applicator.

TECHNICAL ASSISTANCE CENTER

CALL TOLL FREE 1-800-722-1111
(CONTINENTAL UNITED STATES AND PUERTO RICO ONLY)

GENERAL MACHINE POLICY

All machines remain the property of AMP Incorporated. The customer shall have no title to the machine(s) and his interest shall be limited to the use of said machine(s) for the purpose indicated, during the stated term, at the specified plant.

No major change or modification shall be made without written consent of AMP Incorporated. Spare and component parts are available at nominal prices.

A list of component parts is included in the instructional material or drawings supplied with each machine.

The customer shall be fully responsible for the maintenance of the machine(s) including servicing, repair, and replacement of damaged or broken parts. Each machine shall be returned in usable condition — reasonable wear and tear excepted. Before returning the machine, contact AMP Incorporated, Harrisburg, Pennsylvania requesting instructions for shipping and disposition.

AMP Field Service Engineers are available to provide assistance in the adjustment or repair of the machine when problems arise which your maintenance personnel are unable to correct. Contact AMP Incorporated Service Products Business for applicable fees.

INFORMATION REQUIRED WHEN CONTACTING SERVICE PRODUCTS BUSINESS

AMP Service Products Business offers the **Technical Assistance Center** as a means of providing technical assistance when required.

When contacting AMP Service Products Business by telephone regarding service to a machine or tool, it is suggested that a person familiar with the device be present with a copy of the manual (and drawings) to receive instructions. Many difficulties can be corrected in this manner.

When calling the Technical Assistance Center, be ready with the following information:

1. Customer name
2. Customer address
3. Person to contact (name, title, telephone number and extension)
4. Person calling
5. Machine or tool number (and serial number if applicable)
6. Product part number (and serial number if applicable)
7. Urgency of request
8. Nature of problem
9. Description of inoperative component(s)
10. Additional information/comments that may be helpful

CONTENTS

| | |
|---|----|
| 1. INTRODUCTION | 1 |
| 2. DESCRIPTION | 1 |
| 2.1. Physical Description | 1 |
| 2.2. Functional Description | 4 |
| 3. RECEIVING INSPECTION AND INSTALLATION | 5 |
| 3.1. Receiving Inspection | 5 |
| 3.2. Machine Requirements | 6 |
| 3.3. Machine Size | 6 |
| 3.4. Machine Weight | 6 |
| 3.5. Production Rates | 6 |
| 3.6. Considerations Affecting Machine Placement | 6 |
| 4. MACHINE OPERATION | 7 |
| 4.1. Terminal Strip Loading and Unloading | 7 |
| 4.2. Production Setup | 8 |
| 4.3. Production Operation | 9 |
| 5. MAINTENANCE | 9 |
| 5.1. Daily Inspection | 9 |
| 5.2. Daily Cleaning | 9 |
| 5.3. Weekly Inspection and Cleaning | 9 |
| 5.4. Monthly Cleaning, Inspection and Lubrication | 10 |
| 6. ADJUSTMENTS | 11 |
| 6.1. Wire Crimp Height Adjustment | 11 |
| 6.2. Insulation Crimp Height Adjustment | 12 |
| 6.3. Terminal Strip Feed Adjustment | 12 |
| 6.4. Strip Guide Plate Bell Mouth and Feed Pawl Adjustments | 13 |
| 6.5. Strip Guide Adjustment | 13 |
| 6.6. Shear(s) and Shear Holder(s) Adjustments | 13 |
| 6.7. Stripping Blade Closure Adjustments | 14 |
| 6.8. Wire Strip Length Adjustment | 15 |
| 6.9. Wire Stop Adjustment | 15 |
| 6.10. Main Cylinder Speed Adjustment | 15 |
| 6.11. Closing Delay Adjustment for Stripping Blades | 15 |
| 6.12. Auto Mode Sensitivity Adjust | 15 |
| 6.13. Stripping Mechanism Speed Adjustment | 15 |
| 7. REPAIR AND REPLACEMENT | 17 |
| 7.1. Applicator Replacement | 17 |
| 7.2. Applicator Upper Tooling Replacement | 17 |
| 7.3. Applicator Lower Tooling (Anvil) Replacement | 18 |
| 7.4. Stripping Blades and Stabilizer Bar Replacement | 18 |
| 7.5. Feed Pawl Replacement | 18 |
| 7.6. Shear Blade and Shear Plate Replacement | 18 |
| 7.7. Crimp Height Repair | 19 |

| | |
|---|-------------|
| 7.8. Pneumatic System Repairs | 19 |
| 7.9. Spare Machine Parts | 19 |
| 7.10. Spare Strip Blades | 20 |
| 8. PARTS LISTS | 20 |
| 9. TROUBLESHOOTING | 20 |
| 10. REVISION SUMMARY | 22 |
| SUPPLEMENT 1 — Pneumatic Counter | S1/1 |

ILLUSTRATIONS

| | |
|--|-----|
| Frontispiece. AMP-O-MATIC Side Feed Stripper-Crimper Model II, 854040-1 and -2 | iii |
| 2-1 Machine Components | 2 |
| 2-2 Typical Applicator | 5 |
| 3-1 Proper Position, Adjustments, and Locations | 7 |
| 3-2 Materials Location | 7 |
| 4-1 Machine Features — Operation | 8 |
| 5-1 Lubrication Points | 11 |
| 6-1 Terminal Strip Feed Adjustment Location | 14 |
| 6-2 Wire Stop and Stripping Blades Depth Adjustment Locations | 16 |
| 7-1 Spare Machine Parts | 19 |
| 7-2 Standard Strip-Blade Application Chart | 20 |

1. INTRODUCTION

This manual provides the information required for operation and maintenance of AMP-O-MATIC Side Feed Stripper-Crimper Machine No. 854040-1 and -2. Information includes: description; receiving inspection and installation; machine operation; preventive maintenance; adjustments; repair and replacement; and Documentation Package. The -2 machine is available with the Crimp Quality Monitor (CQM). For further information, contact your AMP Field Representative.

NOTE *All measurements in this document are in metric units [with U.S. customary units in brackets].*

The compact 68 kilogram [150-lb] (approximate) machine is intended for bench-top operation. The size is approximately 355 mm wide x 457 mm deep x 838 mm high [14 in. wide x 18 in. deep x 33 in. high], including the reel support (less terminal reel). For operation, the machine requires a constant air supply of 552 to 690 kilopascals (kPa) [80 to 100 psi] with adequate volume (1.6 liters/sec. [3.5 scfm]) to maintain a minimum of 552 kPa [80 psi] throughout the cycle of operation. No electrical power is required for machine operation but is required for the worklamp to light the "target area."

NOTE *Retain all Documentation Packaging, 854260-1, for reference and ordering replacement parts.*

Refer to Section 10, REVISION SUMMARY, for a description of this document's revisions.

When ordering replacement parts, contact:

CUSTOMER SERVICE (38-35)
AMP INCORPORATED
P.O. BOX 3608
HARRISBURG, PA 17105-3608.

Although not supplied or sold by AMP Incorporated, a pneumatic counter can be installed by the customer. Refer to the supplement in the back of this manual.

When reading this manual, pay particular attention to DANGER, CAUTION, and NOTE statements.

DANGER *Denotes an imminent hazard which may result in moderate or severe injury.*

CAUTION *Denotes a condition which may result in product or equipment damage.*

NOTE *Highlights special or important information.*

For information beyond the scope of this manual call or contact:

SERVICE PRODUCTS BUSINESS
AMP INCORPORATED
P. O. BOX 3608
HARRISBURG, PA 17105-3608
Technical Assistance Center: 1-800-722-1111

2. DESCRIPTION

2.1. Physical Description (Figure 2-1)

The machine is supported on four leveling pads and is totally enclosed in a plastic cover, except for the reel support which extends above for easy installation of terminal reels. The terminal strip from the reel passes around the stock guide on the left side of the machine, then enters the applicator inside the front door. The front door is hinged for easy access to the applicator tooling and "target area" which is visible through the clear door. During operation, wires are inserted through the opening in the window into the "target area" for termination.

The machine consists of five major assemblies: the machine assembly, wire gripper assembly, stripper assembly, air-valve assembly, and filter/regulator assembly. Descriptions of the assemblies are included in this manual. Also included is a description of typical side-feed applicator used in the machine.

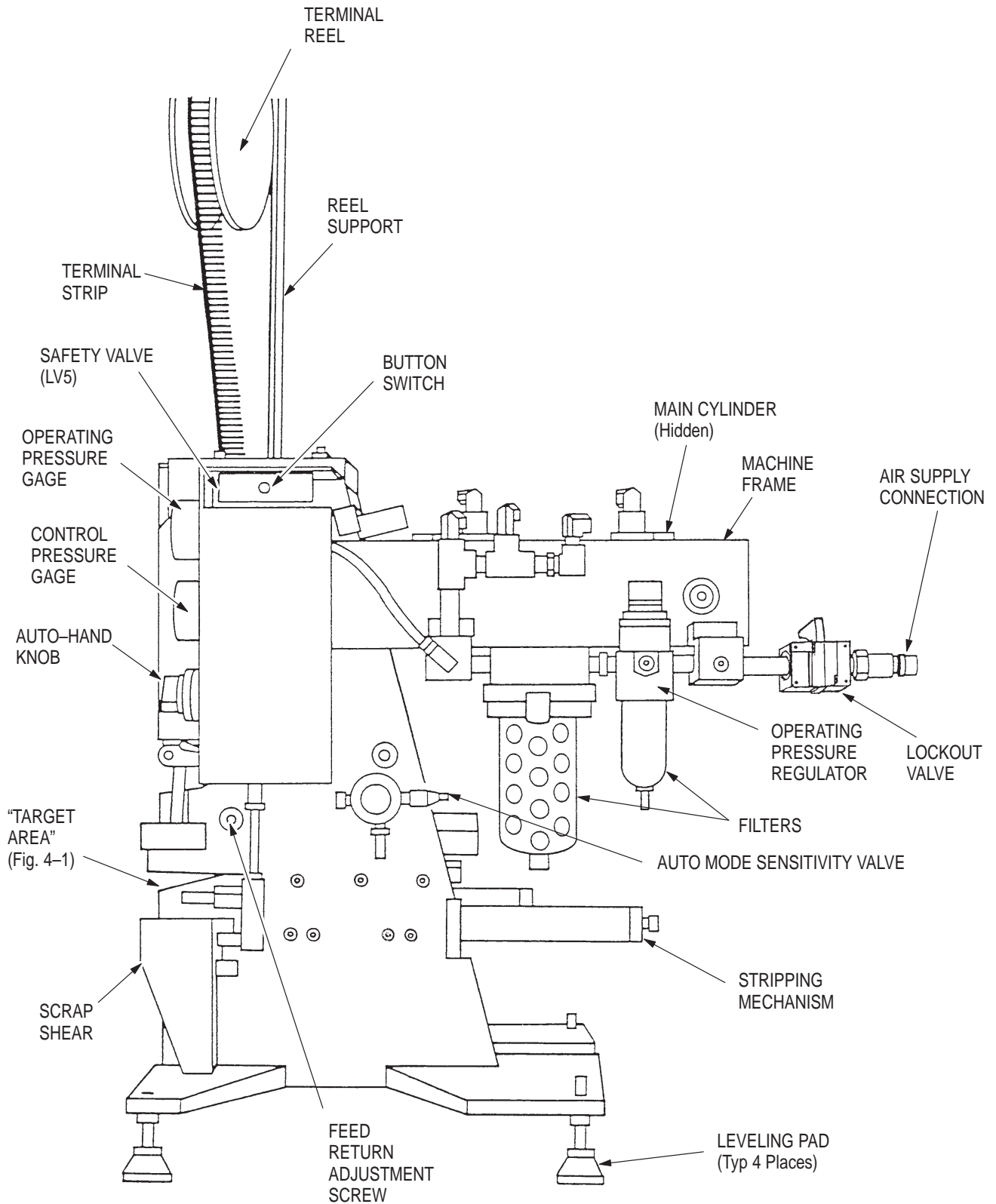

Figure 2-1. Machine Components (Sheet 1 of 2)

91-99B

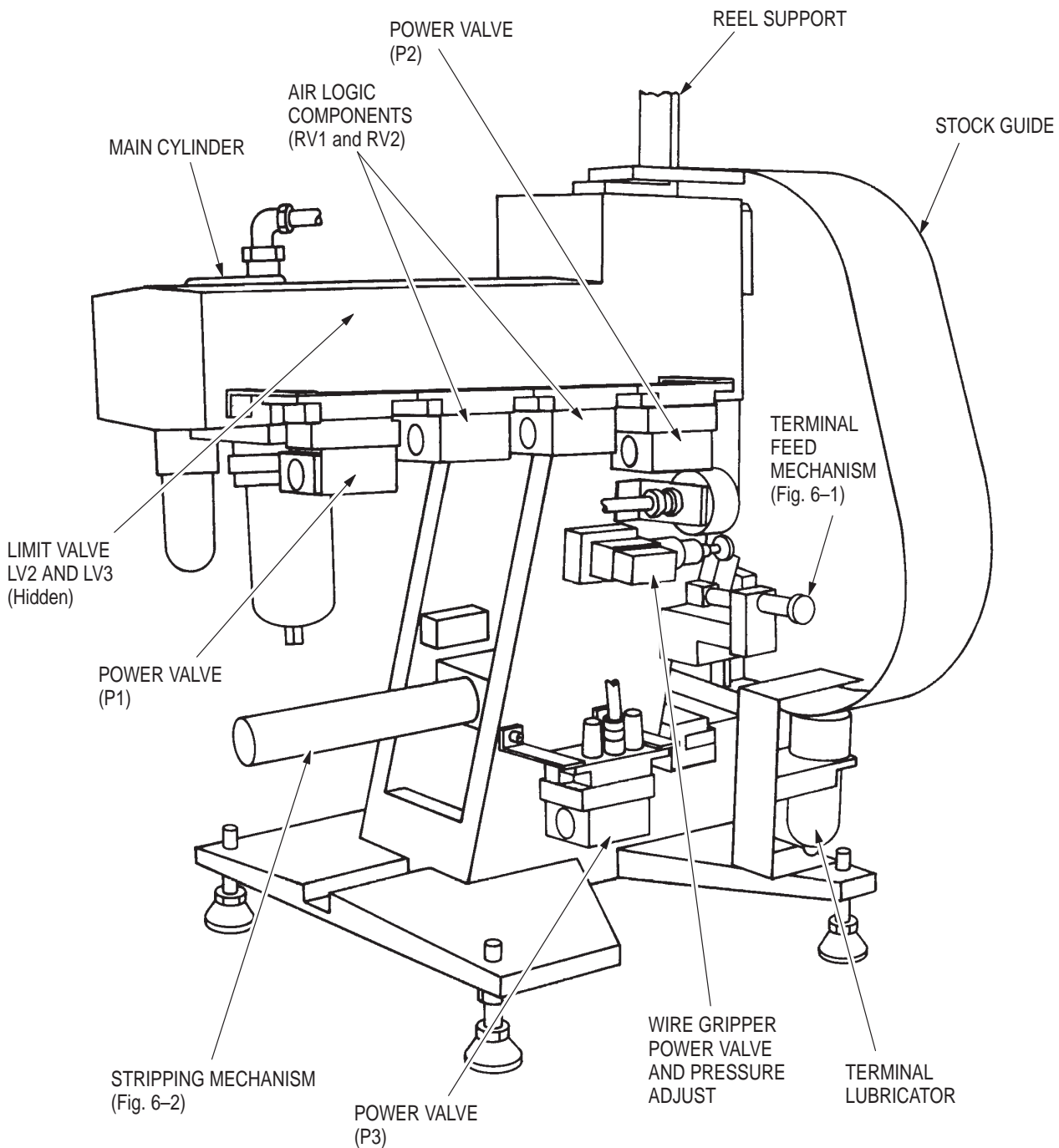

Figure 2-1. Machine Components (Sheet 2 of 2)

91-100A

NOTE This machine is provided with a lockout valve. This disables the machine to prevent injury while troubleshooting or performing maintenance. When the valve is in the closed position, a hole allows installation of a lock.

A. Machine Subassembly

The machine assembly consists of a cast frame which provides the mounting facilities for the pneumatic system and the mechanically operated components, including the applicator. Between the vertical frame members is the main cylinder which provides the power required by the applicator for crimping the terminals. This is accomplished through linkage to the ram which is directly connected to the applicator ram. The linkage is also mechanically connected to the terminal feed mechanism, and the scrap shear for operation during the crimping cycle.

The front of the frame provides the mounting facilities for the easily replaced applicators. In front of the applicator is the wire gripper assembly which is actuated by an air cylinder to secure the wire during the stripping and crimping action.

The lockout valve, extending through the back of the machine cover, supplies air pressure to the two filters and one regulator mounted on the right side of the frame. The gages are readable through the clear door. *No air line lubricator is required* because the cylinders and valves are designed to operate on dry air. The air logic components are mounted on the left side of the frame. The terminal feed mechanism is also mounted on the left side of the frame in alignment with the applicator. It is actuated by the applicator ram to feed the terminal strip into the "target area." A terminal lubricator assembly is included with the machine.

B. Stripping Mechanism Subassembly

Beneath the main cylinder, and between the vertical frame members is the stripping mechanism which slides in gibs. The stripping blades are actuated (closed and opened) by the stripping cylinder mounted at the back of the mechanism. After closing of the blades, the mechanism is moved to the rear by a separate air cylinder, to strip the insulation from the wire being terminated. The wire sensor, acting as a wire stop, is mounted at the back of the strip blades. When the machine is being operated in the automatic mode, selected by the AUTO-HAND knob on the front of the machine, the wire placement is detected by the wire sensor and automatically cycles the machine, provided that the foot valve is being held depressed. The use of the sensor ensures exact positioning of the wire for each termination.

C. Applicator (Typical, Figures 2-2 and 6-1)

The side feed applicators used in this machine are the pre-feed type, and are interchangeable to provide a wide range of terminations. The crimpers, anvil, and the rear floating shear (when used) are the same as those used in the heavy duty miniature quick-change applicators. The upper portion of the applicator is the applicator ram containing the upper tooling. The lower portion is the base plate which supports the anvil (lower tooling), the strip guides, and the stock drag. The upper and lower portions have identification tags which carry identical serial numbers to prevent mixing of portions with those of other applicators.

The applicator ram is held in the machine frame by a ram cap. The ram post is inserted between the bosses of the machine ram which contact a pair of pads on the wire disc. There may be as many as four pairs of pads (A through D – each pair is a different height) to provide four different crimp heights per applicator. Refer to the applicator parts list for applicable setting per wire size. The pad letter visible at the front and center of the applicator indicates the setting to obtain the specified crimp height. Under the wire disc is the insulation disc (when applicable) which has eight pads (1 through 8) on the bottom side. Each pad is a different height. The lowest number is for the loosest crimp. Each pad, when aligned with the insulation crimper, provides a different insulation crimp height. The wire crimper, insulation crimper, spacers, and front shear depressor are attached to the ram by the crimper bolt. The wire crimper is stationary in relation to the ram, while the insulation crimper is free floating to permit variations between the two crimpers. On the back of the ram is the cam which operates the terminal feed mechanism.

The lower portion of the applicator is positioned on the machine base plate by two dowel pins and retained with quick release left and right hold-downs. So that both pins and sockets may be terminated in the applicator without re-adjusting each time, the applicator provides an adjustment for the strip guide plate, and also the scrap guide. These may be adjusted to minimize the effects of differences in camber of the various carrier strips. The design of the front floating shear is unique to this applicator.

NOTE

The terminals used with the applicators in this machine are reeled the same as those for AMP Miniature Quick-Change Applicators.

2.2. Functional Description

It shall be assumed that the machine has been properly installed, loaded with terminals, connected to the air supply, and is ready for production operation as described in Section 4.

The following sequence describes the machine through one complete cycle of operation. Refer to the pneumatic diagram, drawing 854258 in the Document Package, for sequence of component operation.

1. If the machine is being operated in the automatic mode, the operator depresses and holds the foot valve. This step does not apply for the manual mode of operation.
2. Operator inserts the wire through window into "target area" until it contacts the wire sensor (wire stop), keeping wire as low and horizontal as possible.

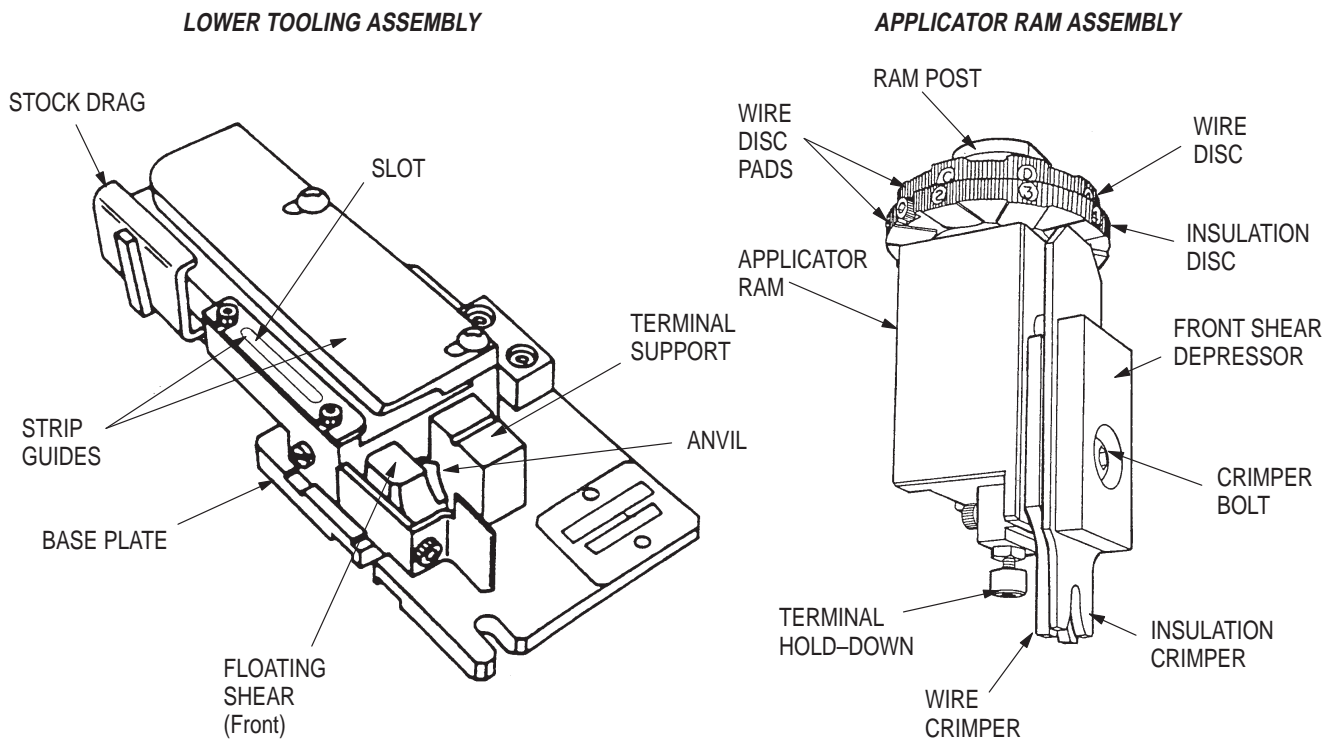

Figure 2-2. Typical Applicator

91-101A

3. If machine is being operated in the manual mode, operator depresses foot valve momentarily to start machine cycle. In the automatic mode, the machine starts to cycle when the wire contacts the wire sensor, providing the foot valve is depressed.
4. Wire grippers close to secure wire and stripping blades close to cut insulation.
5. Stripping mechanism starts to rear, pulling insulation from wire.
6. Ram starts to move downward.
7. As ram fully bottoms, it crimps the terminal onto the wire. Stripping blades and wire grippers open.
8. Ram is raised to its original position, the terminated wire is released.
9. The stripping mechanism is moved toward the front after an adjustable delay for wire removal.

3. RECEIVING INSPECTION AND INSTALLATION

3.1. Receiving Inspection

The machine is thoroughly inspected during and after assembly. Before it is shipped, a final series of tests and inspections is made to ensure proper functioning. Still, the following inspection should be performed as a safeguard against problems generated during shipment.

1. Carefully uncrate the machine and place it on a sturdy bench where there is enough light to permit a careful examination.
2. Remove the cover, and thoroughly inspect the entire machine for evidence of damage that may have occurred during transit. If the machine is damaged, file a claim against the carrier and notify AMP Incorporated immediately.
3. Check all components and parts to be certain they are secure.
4. Check wiring for loose connections and for frayed or broken wire and insulation.
5. Check all air lines for evidence of loose connections or damage.

3.2. Machine Requirements

A. Electrical

115 Vac. 60 Hz single-phase power with separate ground.

B. Air Supply

The machine requires a constant air supply of 552 to 690 kilopascals (kPa) [80 – 100 psi] with adequate volume 1.6 liters/sec. [5 scfm] to maintain a minimum of 552 kPa [80 psi] through the cycle of the operation.

3.3. Machine Size

The size is approximately 355 mm wide x 457 mm deep x 838 mm [14 in. wide x 18 in. deep x 33 in. high] including the reel support (less the terminal reel).

3.4. Machine Weight

The weight is 68 kilograms [150 lb.] approximately.

3.5. Production Rates

Average acceptable finished assemblies per hour:

1. 1000/hour for 24 AWG jacketed cable with prepared breakout of 25.4 mm [1 inch].
2. 1400/hour for discrete wire.

3.6. Considerations Affecting Machine Placement

Proper location of the machine in relation to the operator is essential to both safety and efficiency. Studies have repeatedly shown that fatigue will be reduced and efficiency increased if particular attention is paid to the bench, the operator's chair, and the placement of the foot valve if one is used.

A. Bench

A sturdy bench 711 to 762 mm [28 to 30 in.] high aids comfort by allowing the operator's feet to rest on the floor and the weight and leg position to be easily shifted. The bench should have rubber mounts to reduce noise. The open area under the bench should allow the chair to slide far enough in for the operator's back to be straight and supported by the back rest.

B. Machine Location on Bench

The machine should be located near the front of the bench, and the machine work area (the area where the product is applied) should be 152 to 203 mm [6 to 8 in.] from the front edge. Access to the back of the machine must be provided for maintenance purposes in most cases.

C. Operator's Chair

The operator's chair should swivel, and the seat and back rest should be padded and independently adjustable. The back rest should be large enough to support the back both above and below the waist.

In use, the chair should be far enough under the bench so that the operator's back is straight and supported by the back rest.

D. Foot Valve (When Used)

When the operator is correctly positioned in front of the machine, the foot should rest on the valve comfortably and easily. The valve should be placed on a rubber mat; this allows it to be movable and permits the operator to shift positions to minimize fatigue, while at the same time the mat prevents the valve from sliding unintentionally.

The preference for locating the foot valve varies among operators. Some like the valve located so that their foot rests on the valve when their legs are in the natural sitting position (calf perpendicular to the floor). Others

prefer it slightly in front of the natural position. The important thing is that the foot be about 90° to the calf when resting on the valve. Those who prefer the valve slightly forward may require a wedge-shaped block placed under it.

Figure 3-1 shows proper location and position. Figure 3-2 shows a typical layout for the efficient handling of materials.



Figure 3-1. Proper Position, Adjustments, and Locations

Figure 3-1 shows the physical considerations as recommended, and the operator in a desirable position. Note that with the chair height and back rest properly adjusted and the chair properly located, the operator's back is straight and supported by the chair and the upper arms are in direct line with the torso.

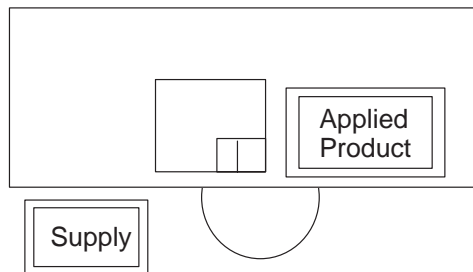

Figure 3-2. Materials Locations — Plan View

Figure 3-2 is a typical plan view to illustrate the convenience to handling of materials afforded by the proper setup.

4. MACHINE OPERATION

This section pertains to loading and unloading of terminal strip, and operation of the machine in production use. It shall be assumed that the machine has been properly installed in accordance with Section 3.

4.1. Terminal Strip Loading and Unloading (Figure 4-1)

A. Loading

1. Place reel of terminals on reel support and secure with flange. Strip must unreel and enter left side of machine with wire barrels of terminals toward front of machine and with open "U" up.
2. Turn drag release lever upward to raise stock drag.
3. Feed terminal strip through strip guides until lead terminal is over anvil, then pull back slightly on strip to assure feed pawl is properly engaged in feed point of strip.
4. Turn drag release lever down to apply drag to terminal strip.
5. After making several terminations, make sure carrier strip enters scrap shear to the right of applicator.

B. Unloading

1. Release stock drag.
2. While raising and holding feed finger up, pull terminal strip back through strip guides until clear.
3. Roll terminal strip onto reel to prevent distortion until loaded again into machine.

4.2. Production Setup (Figure 4-1)

1. Check the wire disc pad settings and stripping blades for sizes of wire to be run.
2. Place an adequate supply of wire within easy reach of the operator's position.
3. Be sure that an adequate supply of terminals is on the reel.
4. Connect air supply to machine and lift lockout valve to "open". Turn work light on.

DANGER Machine assembly may move when the air is turned on.

5. Check operating pressure for 552 kPa [80 psi].
6. Select the desired mode of operation with AUTO-HAND knob on front of machine.

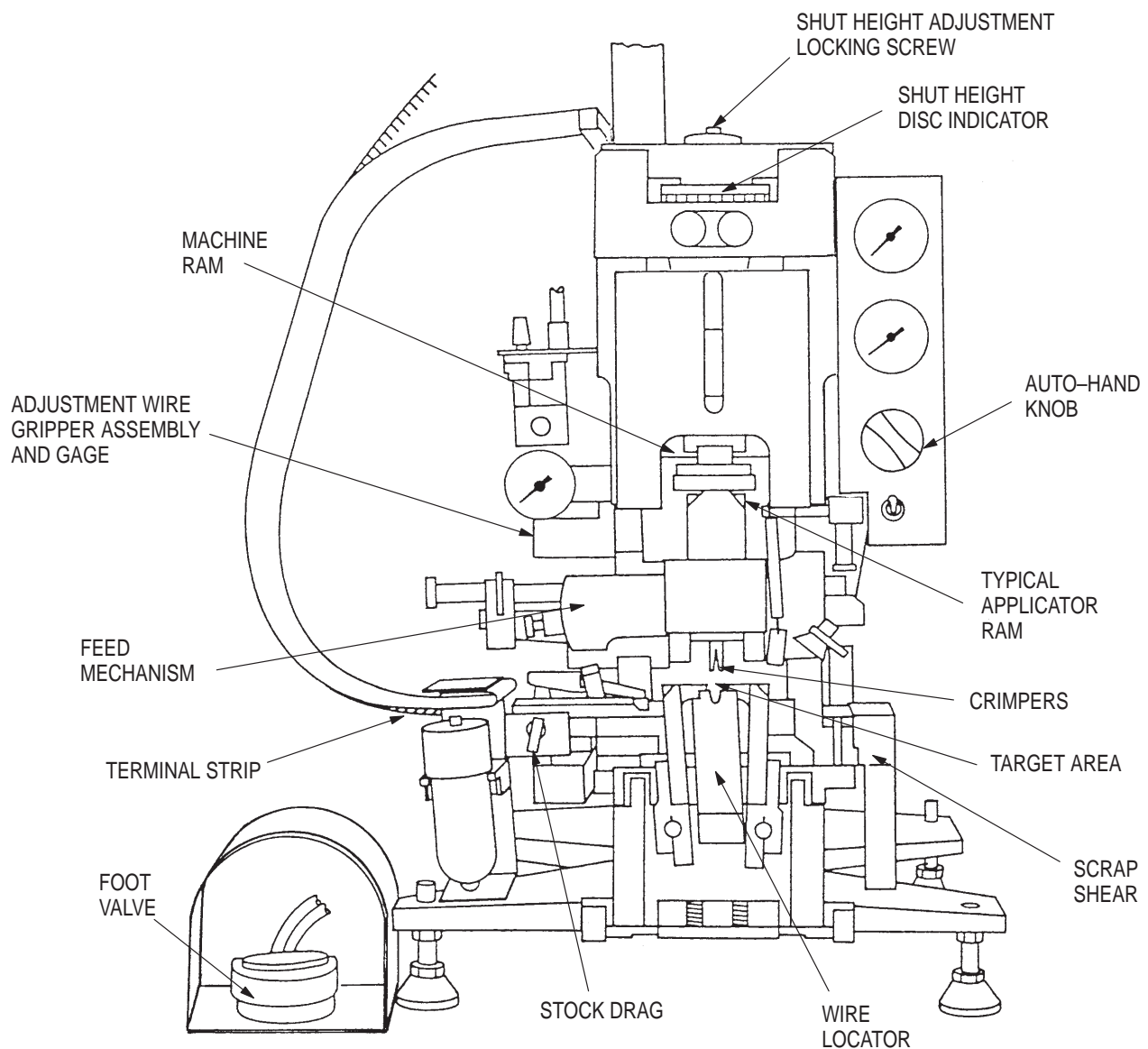

Figure 4-1. Machine Features – Operation

91-102D

4.3. Production Operation

1. If operating in the automatic mode, depress and hold foot valve.
2. Insert a wire into the “target area” and against wire stop, keeping wire as low and straight as possible (perpendicular to front of machine). If operating in the automatic mode, machine will cycle when wire contacts the wire stop. If operating in the hand mode momentarily depress the foot valve to cycle the machine. Remove terminated wire at end of cycle.

NOTE

If the machine does not cycle in the automatic mode when the wire stop is touched by a piece of wire, refer to the sensitivity adjustment in Paragraph 6.12.

3. Repeat Steps 1 and 2 until desired number of wires has been run. Periodically inspect for proper terminations and for correct crimp height. Measure crimp height as described in instruction sheet 408-7424.
4. At completion of run, slide lockout valve “closed.” This is required so that the pre-filter will drain itself. If machine is not to be used again in a short period of time, disconnect the air supply. Turn work lamp “off.”

5. MAINTENANCE

Maintenance consists of cleaning, inspection, and lubrication of the machine to maintain it in continuous service with a minimum amount of repairs and/or downtime. The frequency of maintenance shall be by shift or weekly and monthly.

DANGER

Before performing maintenance, ALWAYS DISCONNECT LOCKOUT VALVE TO THE machine; turn off the power at the main power switch/circuit breaker. ALWAYS CLOSE LOCKOUT VALVE, to disconnect air supply from machine.

5.1. Daily Inspection

1. Close lockout valve and disconnect the air supply.
2. Open front door.
3. Visually inspect machine for general appearance and functional operation.
4. Close front door.
5. Connect air supply and open lockout valve.
6. Crimp two or more terminals and closely inspect the terminations for evidence of damaged tooling.

5.2. Daily Cleaning

1. Close lockout valve and disconnect air supply.
2. Open front door.
3. Using a small brush, remove all pieces of insulation and carrier strip chips, especially in and around the “target area.”
4. Close front door.
5. Connect air supply.

5.3. Weekly Inspection and Cleaning

1. Close lockout valve and disconnect air supply.
2. Remove machine cover.
3. Check filters in air system for moisture and contamination. The micro filter drains automatically when it reaches a given level.
4. Remove applicator as described in Paragraph 7.1, Applicator Replacement.
5. Thoroughly inspect the machine for loose, damaged, or worn parts. Special attention should be paid to the applicator tooling and scrap shear; replace tooling if necessary as described in Section 7., REPAIR AND REPLACEMENT.
6. Using a small brush, remove all pieces of insulation and carrier strip chips, in and around the entire machine.

5.4. Monthly Cleaning, Inspection and Lubrication

1. Close lockout valve, and disconnect the air supply.
2. Remove the machine cover and applicator ram.
3. Remove the stripping assembly.
 - a. Thoroughly clean both the stripping assembly and the area in and around the gibs.
 - b. Inspect stripping assembly for damaged parts.
 - c. Lightly oil the blade holders.
 - d. Remove excess lubricant.
4. Install the crimping assembly.
5. Remove the wire grippers.
 - a. Thoroughly clean the assembly, removing all insulation strip ends and wire strands. Pay particular attention to the area between the gripper actuator levers and the air cylinder housing.
 - b. Inspect the assembly for worn or damaged parts; replace if required.
 - c. Lightly oil all pivot points.
 - d. Check the grippers for proper alignment and adjust if required.
6. Install gripper assembly.
7. Using a grease gun with multipurpose grease, lubricate the two fittings for the stripping mechanism slide and the three fittings on the ram linkage, (Figure 5-1). To locate the two fittings for the slide mechanism, see Figure 6-2; to gain access to some of these fittings, the ram (not shown) must be at the bottom of its stroke.
8. Apply a few drops of oil to all pivot points using SAE 20 (nondetergent) oil.
9. Fill terminal lubricator with lubricant part number E805 from:

STONER INCORPORATED
PO BOX 65
QUARRYVILLE, PA 17566
Phone: 717-786-7355
10. Remove excess lubricant.

NOTE *DO NOT USE AIR LINE LUBRICANT. All cylinders and valves are designed to operate on clean dry (unlubricated) air.*

11. Apply a thin film of grease to the four corners of the applicator ram and the face of the feed cam.
12. Install applicator and ram as described in Section 7, REPAIR AND REPLACEMENT.
13. Install machine cover.
14. Load terminals in applicator as described in Section 4, MACHINE OPERATION.
15. Connect air supply and open lockout valve.
16. Close front door.
17. Operate the machine as described in Section 4 to determine if the unit is operating properly.

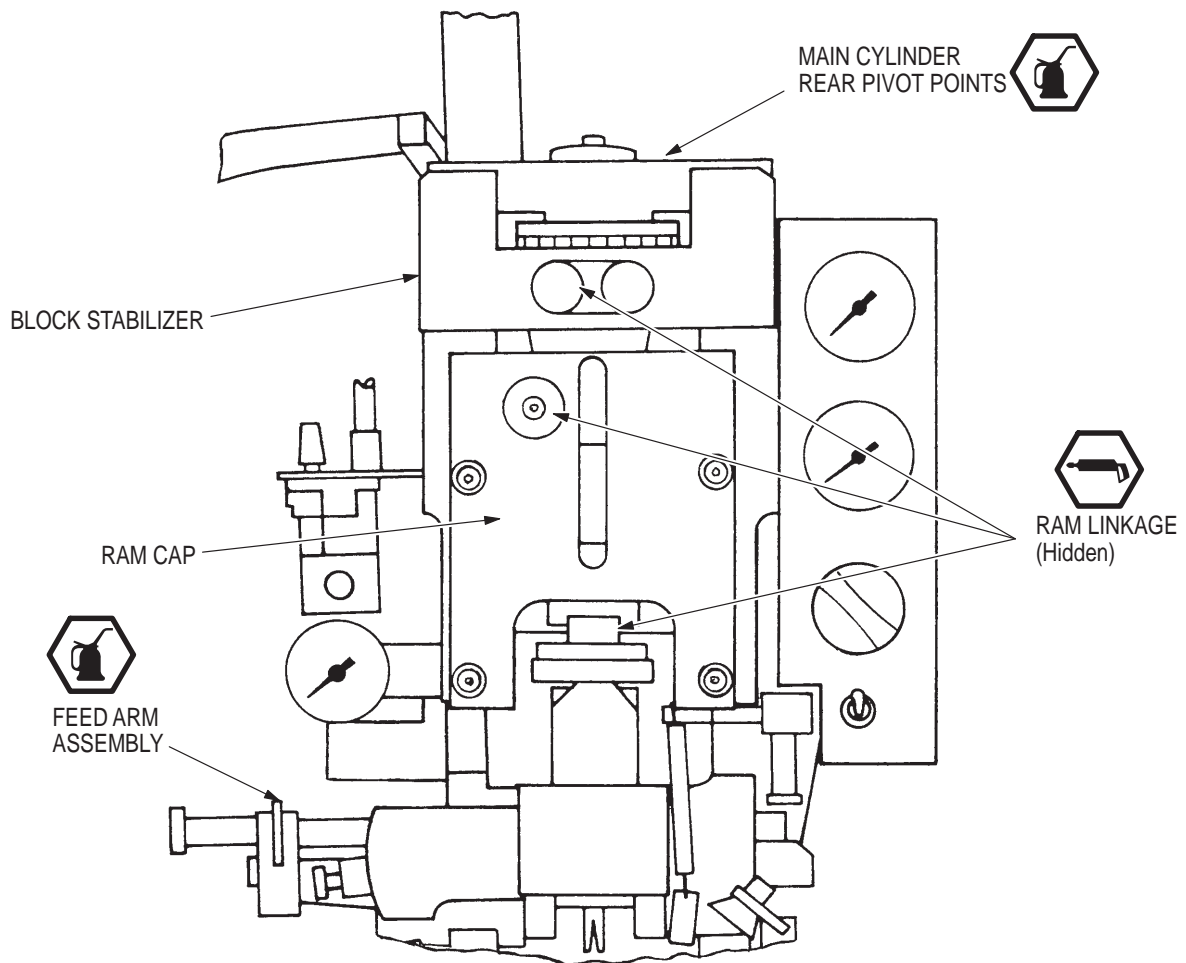

Multipurpose grease.



SAE 20 nondetergent oil.



SAE 5 or 10 nondetergent, nonsynthetic oil.

Figure 5-1. Lubrication Points

91-102E

6. ADJUSTMENTS

The following adjustments may be necessary to maintain the machine in continuous service, or in the event it is necessary to replace parts and/or components.

DANGER

Before performing maintenance, ALWAYS DISCONNECT POWER to the machine; turn off the power at the main power switch/circuit breaker. ALWAYS CLOSE LOCKOUT VALVE, to disconnect air supply from machine.

6.1. Wire Crimp Height Adjustment (Figure 2-2)

1. Open front door of machine to gain access.
2. Select pad letter (A, B, C, or D) specified on Applicator Parts List (Log), supplied with the particular applicator installed in machine, for AWG wire size and terminal being used.
3. Turn wire disc (upper disc) so that selected pad letter is visible to FRONT and center of applicator. This provides the proper crimp height for terminal and wire size being used.

4. After making insulation crimp adjustment as described in Paragraph 6.2, make several test crimps by operating machine as described in Section 4, then perform the following:
 - a. Inspect terminations for rough or sharp edges around crimped barrels (flash), deformed crimps, bent terminals, or other defects caused by worn or broken tooling. If necessary, replace tooling as described in Section 7.
 - b. If terminations appear normal, measure crimp height of each termination as described in instruction sheet 408-7424. Crimp height must agree with measurement specified on Applicator Parts List (Log) supplied with the applicator being used. Record crimp height dimensions for reference.
 - c. If crimp height is INCORRECT, remove applicator and install one that is Known to produce terminations of CORRECT crimp height, as described in Paragraph 7.1. Make several test crimps and repeat Step b. If crimp heights are still INCORRECT for this applicator, the problem is machine shut height (see Step d). Contact your AMP Field Service Engineer, or the AMP Technical Assistance Center: 1-800-722-1111. If the crimp height is CORRECT for this applicator, problem is in original applicator, and crimp height repair is described in Section 7.
 - d. The "shut height fine adjust" may be used, for example, when an applicator is not properly shimmed for the machine shut height setting. The factory set machine (854040) is 135.79 mm [5.346 in.]. To fine adjust the shut height, unlock the screw adjust (31, Figure 4-1). Insert dowel pin into holes of disc indicator (33) and move as required; Each increment on disc indicator is 0.013 mm [.0005 in.].
5. During extensive operation, periodically repeat Step 4 to make sure applicator is producing correct terminations.

6.2. Insulation Crimp Height Adjustment (Figure 2-2)

The insulation crimp height adjustment (when applicable) must be made in relation to wire crimp height as described in Paragraph 6.1. To adjust, turn insulation disc (lower disc) to align number (1 through 8) with top of insulation crimper on applicator ram. The loosest crimp is produced at No. 1 setting and the tightest at the No. 8 setting. To find a satisfactory insulation crimp for any wire insulation outside diameter, start with No. 1, making test crimps. Increase setting one number at a time until desired crimp height is obtained. The crimp should hold the insulation firmly without cutting into it.

6.3. Terminal Strip Feed Adjustment (Figure 6-1)

Proper adjustment of the terminal strip feed is achieved when the applicator ram is fully raised and the feed finger is fully extended to CENTER the lead terminal over the anvil. Adjustment may be necessary (especially when changing applicators) due to variations in the feed points of different terminal strips. The location of the pivot shaft in the adjusting plate for the feed arm may be a determining factor to obtain proper adjustment. There are three adjustment positions in which the pivot shaft may be located. In most cases the middle hole is used. The bottom position provides the SHORTEST feed finger stroke and the top position provides the LONGEST. When performing the following procedure, and it is impossible to obtain the proper adjustment, determine if a LONGER or SHORTER stroke is required.

1. Determine which direction the lead terminal must be moved (advanced or retracted).
2. Loosen small lock knob under larger adjusting knob. See Figure 6-1.
3. To advance lead terminal, turn forward limit adjustment knob COUNTERCLOCKWISE. To retract, turn knob CLOCKWISE.

NOTE *When making adjustment, keep terminal strip pulled back against feed pawl, especially during retraction adjustment.*

4. At completion of adjustment, tighten lock screw.
5. Make several test crimps by operating machine as described in Section 4. Observe for proper feeding of terminal strip and centering of lead terminal over anvil. Check retraction of feed finger for slight overtravel of feed point in terminal strip. If no overtravel exists, or if excessive, perform Step 6. If satisfactory, adjustment is complete.
6. For more feed return, turn feed return adjustment screw OUT (refer to Figure 2-1). For less, turn it IN. Perform several test crimps while making adjustment to assure feed return is proper.

6.4. Strip Guide Plate, Bell Mouth, and Feed Pawl Adjustments (Figure 6-1)

This procedure moves the plate on which the strip guides are mounted. Since the terminal strip is fed into the “target area” from between the strip guides, it is moved toward the front or back when the plate is moved in either direction. The adjustment of the feed pawl to match any change in the position of the front strip guide is also described here.

1. Determine the direction and amount of adjustment required.
2. From bottom side of base plate, loosen screw securing strip guide adjustment block to strip guide plate.
3. Turn strip guide plate adjustment screw in the direction and the amount required, as determined in Step 1. CLOCKWISE moves the terminal strip toward the rear, COUNTERCLOCKWISE moves it toward the front. With a piece of terminal strip inserted, and the lead terminal over the anvil, the insulation barrel of the lead terminal should be as close as possible to the floating shear. Tighten screw to secure strip guide plate to strip guide adjustment block after adjustment.
4. Adjust feed pawl by loosening screw securing it to feed finger (holder). Move feed pawl toward front or back until it drops FREELY into slot in front strip guide, then tighten screw to secure.

6.5. Strip Guide Adjustment (Figure 6-1)

This adjustment is not often required, because it is only needed when the strip guides are not parallel to each other, or when there is a variation in the strip width.

NOTE

The strip guides were correctly positioned on the strip guide plate when the applicator was built, and normally do not need adjustment. DO NOT use this procedure for front-to-rear positioning of terminal strip; refer to Paragraph 6.4.

1. Open front door.
2. Wedge feed pawl up to clear front strip guide.
3. Loosen screws securing strip guides to strip guide plate.
4. Move one or both strip guides as required, making sure they are parallel with each other, then tighten screws to secure.
5. Check guides to be sure they are parallel, and that terminal strip can move freely between them with a minimum amount of clearance. Repeat Step 4 if necessary.
6. Adjust feed pawl as described in Paragraph 6.4.

6.6. Shear(s) and Shear Holder(s) Adjustments

NOTE

The front floating shear should be just far enough from the anvil to allow it to move freely up and down. If in this position, it should not require adjustment. The rear shear is more likely to need adjustment because of possible differences in terminal strip widths.

1. Remove applicator ram.
2. Close lockout valve and disconnect air supply.
3. Open front door.
4. Remove lower portion of applicator as described in Section 7.
5. With a length of terminal strip inserted, and the lead terminal over the anvil, check to see if floating shear(s) will cut terminal from carrier strip at the proper location(s). If necessary, make the following adjustment.
6. From bottom side of base plate, loosen screws securing shear holder to base plate, then move shear holder and shear in the desired direction. Tighten screws after adjustment to secure shear holder.
7. Repeat Step 5 to be assured of proper adjustment.

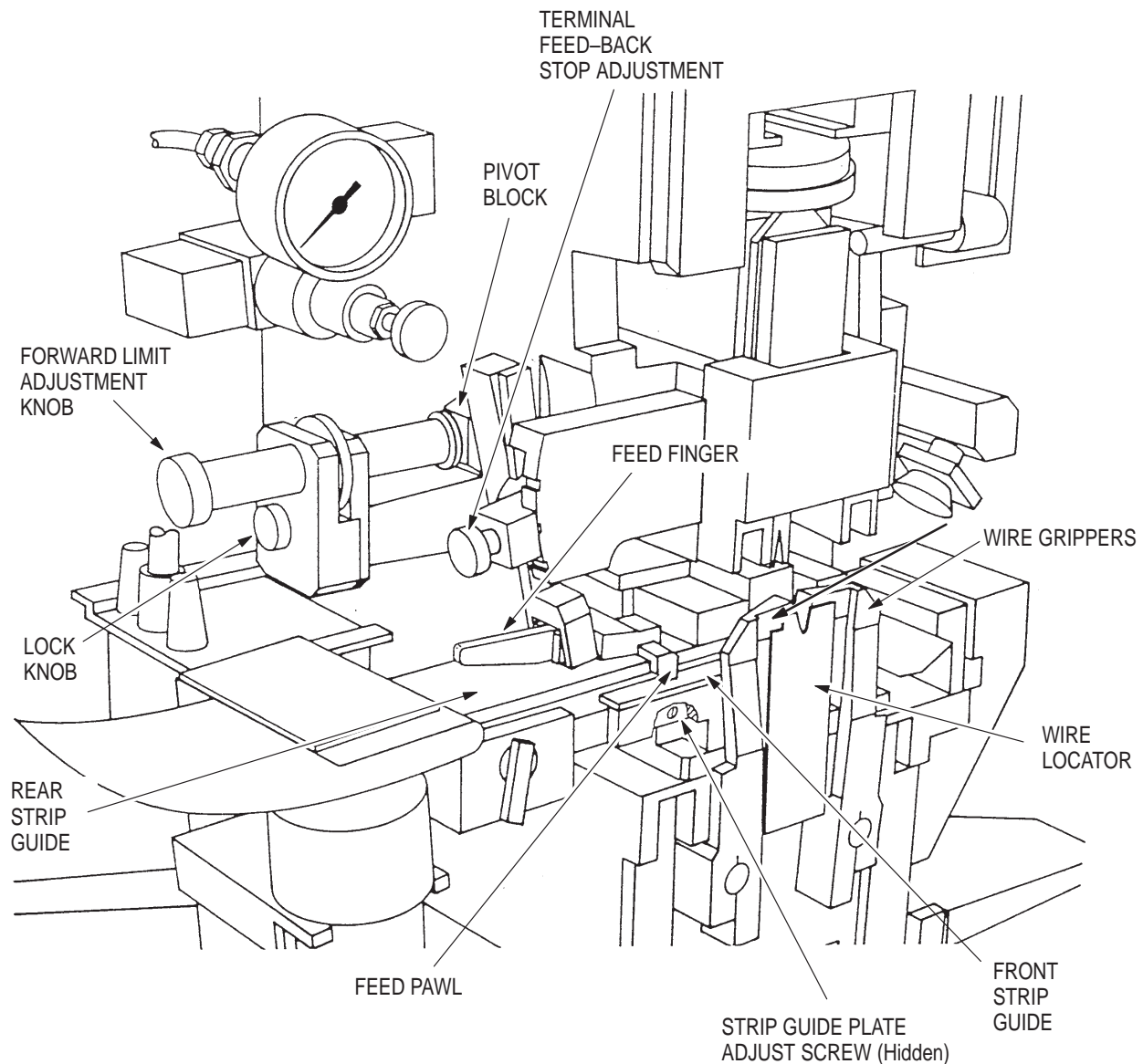

Figure 6-1. Terminal Strip Feed Adjustment Locations

91-103B

6.7. Stripping Blade Closure Adjustment (Figure 6-2)

The stripping blades must be adjusted to a depth that will permit them to cut the insulation and strip it from the conductor, but they **MUST NOT** nick or scrape the conductor during cutting or removal of insulation. When changing from one wire size (AWG) to another, it will be necessary to adjust the closure. Adjust stripping blade depth as follows:

NOTE

This machine has been set up for stripping 24 AWG Teflon[†] insulated wire. Stripping blades for stripping the middle wire size specified on the parts list are supplied with the applicator.

1. Open front door to gain access.
2. Insert blade of screwdriver into strip blade closing adjustment screw. For more closing (smaller wire), turn screw **CLOCKWISE**. For less closing (larger wire), turn screw **COUNTERCLOCKWISE**.

CAUTION

DO NOT turn adjusting screw more than a few degrees ("clicks") at a time between test crimps, especially when adjusting for greater depth, to avoid dulling stripping blades by cutting or scraping conductor.

3. Close front door of machine after completing adjustment.

[†] Trademark of E. I. DuPont de Nemours & Co.

4. Make several test crimps by operating machine as described in Section 4 to determine if stripping blade closing is correct.
5. Repeat as necessary Steps 1 and 2. Close front door when adjustment is satisfactory.

6.8. Wire Strip Length Adjustment

The wire strip length required may vary between applicators, and between terminals. When necessary, adjust strip length as follows:

1. Make several test crimps by operating machine as described in Section 4 to determine if a longer or shorter strip length is required.
2. To shorten strip length, turn adjustment screw CLOCKWISE. To lengthen, turn adjustment screw COUNTERCLOCKWISE. This moves the strip blades in relation to the position of the terminal for stripping the insulation between the wire and insulation crimpers. Each "click" is approximately 0.13 mm [.005 in.].

NOTE

Although the wire stop is attached to the stripping mechanism, this adjustment DOES NOT have any effect on the normal location of the wire stop. Refer to Paragraph 6.9 for wire stop adjustment.

6.9. Wire Stop Adjustment (Figure 6-2)

The wire stop has been pre-adjusted at the factory and should not require further adjustment for regular terminals. Adjustment may be required when using wire such as twisted pair, which will be straightened by the action of the stripping blades. Before making this adjustment, make sure that: (1) the terminals are correctly positioned (proper bellmouth and cutoff tab); (2) the strip length adjustment is correct; and (3) the stripping blades are not touching the wire stop.

1. Turn screw CLOCKWISE to move wire stop back or turn it COUNTERCLOCKWISE to move wire stop forward. In either direction, only a few degrees should be sufficient. One full revolution equals approximate 0.81 mm [.032 in.].
2. Perform several test crimps by operating machine as described in Section 4. Inspect terminations, and repeat procedure if necessary.

NOTE

The adjustable wire gripper subassembly allows regulation of incoming line pressure for two reasons: 1) to prevent insulation damage to an increased range of wire sizes, insulation types, and thicknesses; and 2) to permit retention of larger-size wire for stripping.

6.10. Main Cylinder Speed Adjustment (See Drawing 854258)

The speed of the ram on the downward stroke is controlled by the flow control adjustment screw on power valve (P2). This is the front screw on the front valve near port "B." Turning the screw CLOCKWISE will slow the stroke. The rear screw on this valve (near port "A") controls the speed on the upstroke.

6.11. Closing Delay Adjustment for Stripping Blades (Figure 2-1)

The machine cover must be removed to perform this adjustment. The stripping blades must not close prior to the closing of the wire grippers. This is controlled by the adjustment screw in the front port (P1B) of the power valve P1 (rear of machine). If the stripping blades are closing before the wire grippers are fully closed, turn the adjustment screw CLOCKWISE as required to slow the closing action of the stripping blades. Re-install machine cover when adjustment is satisfactory.

6.12. Auto Mode Sensitivity Adjust

The auto mode sensitivity valve is on the right side of the machine casting. See Figure 2-1 (Sheet 1 of 2). The adjustment screw is on the rear of the auto sensor. To increase the sensitivity, turn screw COUNTERCLOCKWISE (1/4 to 1/2 turn from closed). To decrease the sensitivity, turn screw CLOCKWISE.

6.13. Stripping Mechanism Speed Adjustment (Figure 2-1)

The speed of the stripping mechanism on the forward stroke is controlled by the flow control adjustment screw on the power valve P3. The screw is on the front near port B.

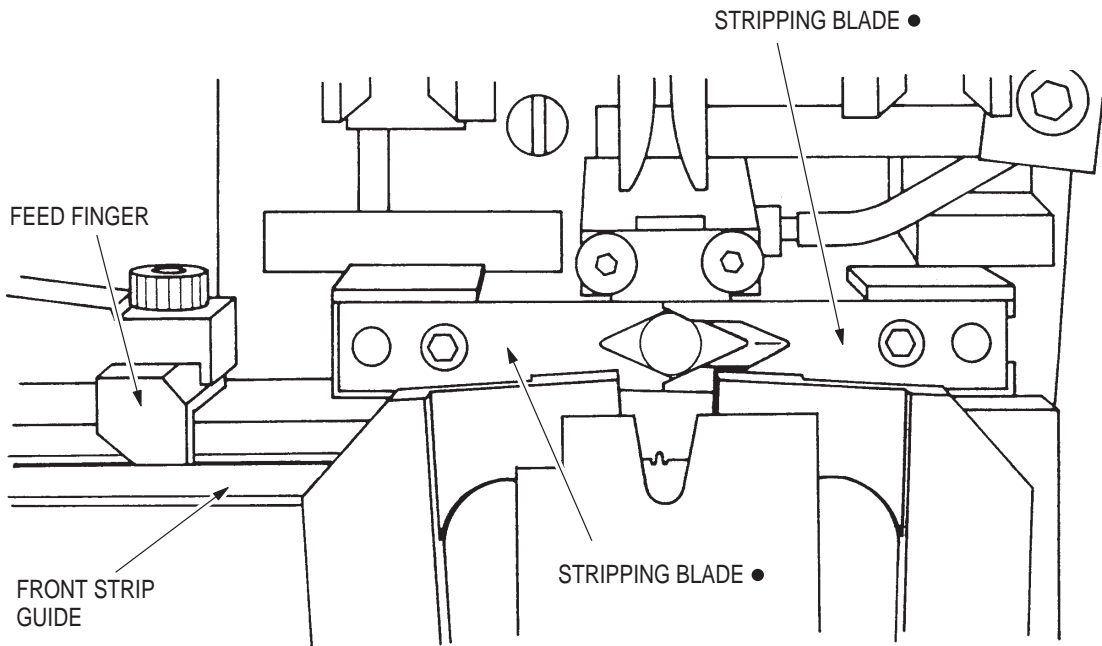
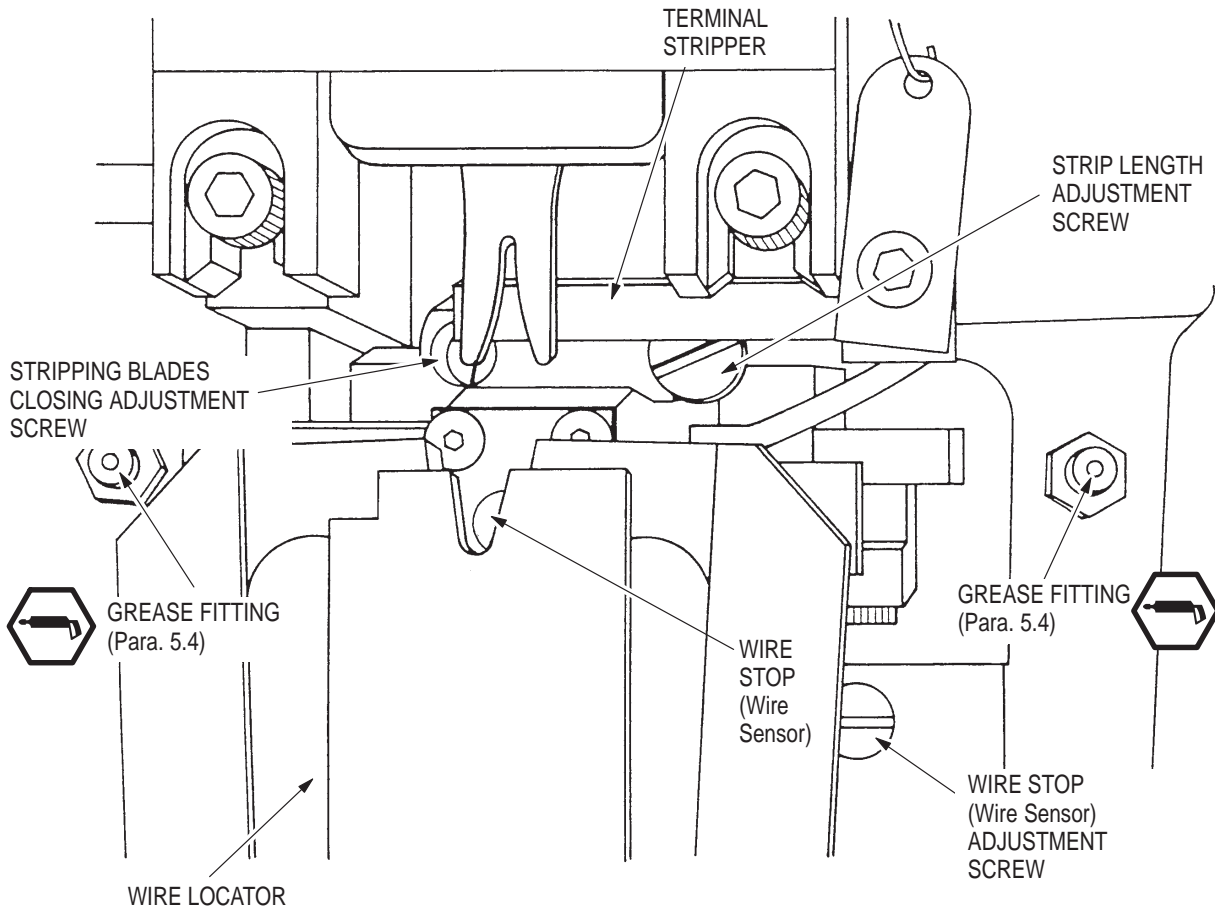

● Not Included with Machine (See Applicator Log).

Figure 6-2. Wire Stop and Stripping Blades Depth Adjustment Locations

99-104, 99-105

7. REPAIR AND REPLACEMENT

This section pertains to making repairs and replacing parts to maintain the machine in continuous service. The following procedures are limited to applicator replacement, tooling replacement in the applicator, and the replacement of machine parts that are recommended spares. Repair information contained herein applies to the pneumatic system, and to correcting the crimp height, when required.

For repairs and replacements not covered in this section refer to the document package. A careful study of the drawing containing the part(s) in question will help to determine the extent of disassembly required to accomplish the repair or replacement. Following re-assembly, refer to Section 6 for adjustments necessary before operating the machine.

DANGER

Before performing maintenance, ALWAYS DISCONNECT POWER to the machine; turn off the power at the main power switch/circuit breaker. ALWAYS CLOSE LOCKOUT VALVE, to disconnect air supply from machine.

7.1. Applicator Replacement (Figure 2-2)

NOTE

If only the applicator ram is to be removed, it is not necessary to remove cover from machine. Just open front door for access.

1. To remove applicator ram from machine, loosen four screws and lockwashers securing ram cap. Pull ram cap upward then forward until clear of machine ram, then lift out. Manually actuate feed mechanism to take pressure off feed cam.
2. Push down lockout valve and disconnect air supply.
3. If removing lower portion of applicator, unload terminal strip as described in Section 4.
4. Ram must be fully raised.
5. To remove lower portion of applicator, perform the following:
 - a. Manually retract stripping mechanism to clear applicator.
 - b. Remove terminal lubricator.
 - c. Rotate hold-down, to the left side of the applicator, CLOCKWISE to release applicator.
 - d. Lift lower portion of applicator to clear alignment pins, then lift feed finger and remove from the left side of machine.
6. Install applicator in machine in the reverse order of removal.

NOTE

After installing lower portion of applicator, momentarily apply air pressure to machine. This will extend stripping mechanism and fully raise machine ram to provide clearance for installing applicator ram.

7. Before operating machine, check applicator adjustments as described in Section 6.

7.2. Applicator Upper Tooling Replacement

The applicator upper tooling consists of a wire crimper and an insulation crimper attached to the applicator ram. To replace, perform the following:

1. Remove applicator ram as described in Paragraph 7.1.
2. Remove crimper bolt securing crimpers and related parts to applicator ram. Note orientation of ALL parts for installation purposes.
3. Install new tooling as required, and re-install applicator ram in the reverse order of removal. DO NOT tighten crimper bolt at this time.
4. Form a piece of heavy paper over anvil.
5. Close flow control at power valve P2B to stop ram, then open flow control 1/4 turn.
6. Connect air supply and open lockout valve. Manually actuate safety valve, LV5 door switch, while pressing foot valve to bring machine ram down slowly under power. Release safety valve and make sure insulation crimper does not strike floating shear.
7. Tighten crimper bolt to secure crimpers in position. Paper over anvil will center crimpers in proper alignment.

8. Open flow control of valve P2B two turns to return ram for production speed, and proceed as follows:
 - a. Temporarily engage LV5 switch.
 - b. Remove paper from over anvil.
9. Load terminal strip and operate machine, as described in Section 4, to check for proper crimping. Make any adjustments deemed necessary.

7.3. Applicator Lower Tooling (Anvil) Replacement

The applicator lower tooling is the anvil attached to the base plate. To replace, perform the following:

1. Remove applicator from machine as described in Paragraph 7.1.
2. Remove screw from under base plate securing anvil. Note orientation of anvil for installation purposes.
3. Install new anvil, and re-install applicator in machine in the reverse order of removal.
4. Loosen crimper bolt and align crimpers as described in Paragraph 7.2.
5. Check applicator adjustments, as described in Section 6, BEFORE operating machine under power.

7.4. Stripping Blades and Stabilizer Bar Replacement (See Drawing 854100)

1. Push down lockout valve and disconnect air supply.
2. Open front door of machine to gain access.
3. Remove screw securing each stripping blade (refer to applicator Parts List), and stabilizer bar (Item No.64) on RIGHT side, to blade mounting blocks. Note orientation of blades and stabilizer bar for installation purposes. Make sure blades are seated in the recess of the blade mounting block.
4. Install new blades and/or stabilizer bar in the reverse order of removal.
5. Adjust stripping blade closure as described in Section 6.
6. Close front door of machine after completing adjustments.

7.5. Feed Pawl Replacement (See Drawing 854040)

The feed pawl (Item No.130) is attached to the feed finger (133) and engages in the feed points of the terminal strip to advance the strip one position for each cycle of the machine. To replace, perform the following:

1. Push down lockout valve and disconnect air supply.
2. Open front door of machine to gain access.
3. Remove screw (131) and washer (127) securing feed pawl to feed finger.
4. Install new feed pawl in the reverse order of removal. BEFORE tightening screw, move feed pawl as required to align tip with feed point in terminal strip. When properly centered in strip guide, the feed pawl can be raised and moved to front or back.
5. Perform several test cycles, by operating machine as described in Section 4, to assure proper feeding of terminal strip and positioning of lead terminals over anvil. If necessary, adjust feed as described in Section 6.

7.6. Shear Blade and Shear Plate Replacement (See Drawing 854040)

1. Push down lockout valve and disconnect air supply.
2. Remove scrap guide, and remove shear assembly from base.
3. To replace shear plate (Item No. 84), remove four screws (85) securing scrap guides (86), (87), and shear plate. Install new shear plate in the reverse order of removal.
4. To replace shear blade (81), remove retaining rings and groove pin, then lift blade out of holder (82). Install new blade in the reverse order of removal.

7.7. Crimp Height Repair

Beneath the insulation disc on top of the applicator ram is one or more washers which may require replacement.

1. Subtract specified crimp height from the average crimp height of those recorded during wire crimp adjustment in Section 6. This will be the thickness of washer(s) (Part No. 690125-1) to be ADDED to thickness of existing washers under insulation disc.
2. Remove applicator ram from machine as described in Paragraph 7.1.
3. Turn ram upside down and secure ram mounting post.
4. Loosen setscrew in side of applicator ram securing ram mounting post, then unscrew ram body from post leaving insulation disc and wire disc in position.

CAUTION

DO NOT REMOVE insulation and wire discs from ram mounting post. There are detent balls and springs installed which may pop out and become lost if discs are removed.

5. Install a thickness of washer(s) on ram mounting post as determined in Step 1. If necessary, replace with completely new washer of a thickness equal to the old washer plus the additional thickness determined in Step 1.
6. Install ram body on post and tighten by hand until snug.
7. Check to determine that numbers on wire disc and letters on insulation disc are properly aligned over insulation crimper. The discs are retained in position by the detent balls. If necessary, turn ram body back slightly until proper alignment is obtained, then tighten setscrew to secure ram body to post.

NOTE

Rotate wire disc and insulation disc to other positions, and when "click" of detent ball is heard in each position, check for centering of letter or number on insulation crimper.

8. Install applicator ram in machine, as described in Paragraph 7.1.
9. Adjust wire crimp and insulation crimp as described in Section 6.
10. Make several test crimps and measure crimp height to assure it is satisfactory before placing machine in service.

7.8. Pneumatic System Repairs

When necessary to make repairs, proper connections, and replace parts, to the pneumatic system, refer to the pneumatic drawing 854258 found in the Document Package.

7.9. Spare Machine Parts

This list includes the wearable parts which are recommended customer spares:

| ITEM | PART NUMBER | DESCRIPTION | QUANTITY |
|------|-------------|--|----------|
| 1 | 6-21084-3 | O-RING, 1/16 in. ID x 1/8 in. OD (Air Detect Nozzle) | 2 |
| 2 | 2-22287-8 | SPRING, Terminal Stripper | 1 |
| 3 | 694433-8 | PAWL, Feed | 1 |
| 4 | 854257-1 | LAMP, Annunciator, Modified | 1 |
| 5 | 982220-1 | O-RING, 1 1/16 x 1 3/16 in. (For Filter Regulator) | 1 |
| 6 | 982220-2 | O-RING, 2 1/8 x 2 1/4 in. (For Micro Air Filter) | 1 |
| 7 | 982220-3 | O-RING, 2 1/8 x 2 5/16 in. (For Micro Air Filter) | 1 |

Figure 7-1. Spare Machine Parts

NOTE

It is customer's responsibility to stock and replace items identified as recommended spare parts in the list above and on the drawings in the machine Documentation Package listed below in Section 8. Refer to the General Machine Policy in the front of the manual.

7.10. Spare Stripping Blades

Stripping blades are a wearable part of any AMP-O-MATIC Stripper-Crimper applicator. To replace standard strip-blades order two of the part number required for your wire size (AWG):

| WIRE SIZE (AWG) | PART NUMBER | WIRE SIZE (AWG) | PART NUMBER | WIRE SIZE (AWG) | PART NUMBER |
|-----------------|-------------|-----------------|-------------|-----------------|-------------|
| 12 | 463310-1 | 18 | 463310-4 | 24 | 463310-7 |
| 14 | 463310-2 | 20 | 463310-5 | 26 | 463310-8 |
| 16 | 463310-3 | 22 | 463310-6 | 28 | 463310-9 |

Figure 7-2. Standard Strip-Blade Application Chart

In addition, special “contour” stripping blades are available to improve stripping of small wires. These blades have an integral wire stabilizing feature and a more efficient cutting profile. They are available for 30 to 32 AWG wire. The selection of these blades depends on wire size, conductor construction (solid, 7 stranded, etc.) and insulation thickness. Contact AMP Engineering in reference to AMP base number 854064.

8. PARTS LISTS (See Document Package 854260-1)

When necessary to order replacement parts for the applicator, ALWAYS refer to the parts list and exploded view drawing supplied with the particular applicator installed in the machine.

When necessary to order replacement parts for the machine, identify the part(s) on the appropriate print in the Document Package by item number, then refer to the corresponding parts list by item number for the part number, description, and quantity required per assembly or subassembly. DO NOT order parts by item number. Item numbers are used for reference ONLY, and are subject to change.

A careful study of the document package drawings, prior to attempting disassembly, will eliminate unnecessary removal of parts when making repairs or replacement.

9. TROUBLESHOOTING

CAUTION

Lockout valve must be closed and air must be disconnected when cleaning, lubricating, or replacing any components, or when repositioning any misaligned parts.

DANGER

KEEP HANDS CLEAR of all moving components (ram, stripping assembly and grippers) during troubleshooting with air pressure applied.

These conditions are required prior to troubleshooting in the hand mode:

1. Air supply connected
2. Lockout valve open
3. Minimum of 552 kPa (80 psi) on gage
4. Front door closed; LV5 activated
5. Remove applicator if it is felt that it may be the cause of the problem.

| PROBLEM | CAUSE | REMEDY |
|---|---|---|
| Machine will not start (No air "HISS" or "POP" at foot valve when depressed). | Air NOT present at RV1, Port A, Line 1 when foot valve is depressed. | Clean or replace blocked filter. Repair blocked or open lockout valve, 552 kPa [80 psij] on meter. |
| | | Defective or OPEN foot valve. Defective "Hand/Auto" switch. S1 Defective. |
| | Air NOT present at RV2, Port 3, Line 2. | Door OPEN. LV5 defective or misadjusted. |
| NOTE: LV5 must be engaged for troubleshooting from this point on. | | |
| | Air NOT present at RV2, Port 2, Line 3, when foot valve is depressed. | Clean/Lubricate or replace RV2. Replace defective LV7. |
| | Air NOT present at P3, Port B, Line 5. | Clean/Lubricate or replace defective RV1. |
| | Gripper and blades WILL NOT close when foot valve is depressed. | Clean/Lubricate or replace defective P1. |
| | | |
| Grippers and blades close, then machine stops. | Air NOT present at P3, Port B, Line 5. | Clean/Lubricate or replace defective LV1. Reposition misaligned LV1. Clean/Lubricate or repair stripping assembly. |
| | Air present at P3, Port B, Line 5. | Clean/Lubricate or replace defective P3. Replace defective retract cylinder. |
| Grippers and blades close, and retract, then machine stops. | Air NOT present at P2, Port A, Line 6. | Reposition misaligned LV6. Replace defective LV6. |
| | Air present at P2, Port A, Line 6. | Clean/Lubricate or replace defective P2. Defective main cylinder; call Technical Assistance Center for assistance. See page 1. |
| Ram down, machine stops, blades and grippers close. | Ram not completely down. | Inspect for loose or binding/broken linkage – lubricate. Defective main cylinder; call Technical Assistance Center for assistance. See page 1. |
| | Air NOT present at P1, Port B, Line 7 | Repair/Replace Defective LV2 |
| | Air is present at P1, Port B, Line 7. | Clean/Lubricate or replace defective P1. Clean/Lubricate or repair stripping assembly. Clean/Lubricate or replace defective strip blade cylinder. |
| | Air is present at P1, Port A, and B. | Clean RV2. |
| Ram down, machine stops, blades and grippers open. | Air NOT present at P2, Port B, Line 8. | Replace defective LV3. |
| | Air is present at P2, Port B, Line 8. | Clean/Lubricate or replace defective P2. Inspect for loose or binding/broken linkage – lubricate. |
| Blades retracted, ram up, machine stops. | Air NOT present at P3, Port A, Line 9. | Repair/Replace defective LV3. |
| | Air is present at P3, Port A, Line 9. | Clean/Lubricate or replace P3. Inspect for loose or binding/broken linkage – lubricate. |

| PROBLEM | CAUSE | REMEDY |
|---|---|--|
| Gripper jaws DO NOT close, machine cycles properly. | No air pressure at Port A of gripper regulator. | Adjust wire gripper adjust assembly. Clean/Lubricate wire gripper adjust assembly. Replace wire gripper adjust assembly. |
| | Air pressure at Port A of gripper regulator. | Inspect wire gripper assembly for broken/worn parts. Clean/Lubricate wire gripper assembly. Clean/Lubricate gripper cylinder. Replace defective gripper cylinder. |
| Machine works in HAND mode, does NOT work in AUTO. | No air bleed at the target area in AUTO mode when footswitch is depressed. | HAND/AUTO selector switch failed or broken. Air bleed needle valve adjusted too low or failed. Blockage of the air nozzle assembly. Air line disconnected from nozzle or damaged. |
| | Excessive air bleed at the target area in AUTO mode with footswitch depressed. | Reduce air flow. |
| | No movement of the target actuator when touched by the wire. | Clean actuator dowel pin. Replace actuator dowel pin. Reduce air flow. Adjust nozzle position. |
| Machine works in AUTO mode, NOT in HAND mode. | Air bleed present at the target area when the footswitch is depressed in the HAND mode. | HAND/AUTO selector switch failed. Clean/Lubricate S1 valve. Replace defective S1. |

10. REVISION SUMMARY

Since the previous of this manual (Rev D), the following changes have been made, primarily due to the removal of -3 and -4 machines to a separate new manual:

Per EC 0150-3221-94:

- Removed reference to -3 and -4 machines from text and figures
- Added NOTE to retain documentation package in Section 1
- Updated customer assistance contacts throughout
- Added NOTE on lockout valve in Section 2
- Revised artwork in Figure 2-2
- Added information to Section 3 and revise
- Revised Paragraphs 4.2 and 4.3, and renumbered procedural steps
- Revised Section 5 and added information
- Added new Figure 5-1
- Expanded DANGER on disconnecting air and power in Sections 5, 6 and 7
- Deleted an adjustment in Section 6, added to new adjustments
- Deleted Figure 6-3
- Deleted five items from Figure 7-1, Spare Machine Parts
- Added Section 9, TROUBLESHOOTING

Per EC 0990-0252-93:

- Changed revision level to Rev E
- Updated revision summary

SUPPLEMENT 1**PNEUMATIC COUNTER****DESCRIPTION**

A pneumatic counter may be installed on the machine to total the machine cycles, and this total equals the number of wire terminations. The counter is not supplied or available from AMP Incorporated, but can be purchased from:

ARO CORPORATION
1 ARO CENTER
BRYAN, OH 43506

When ordering the counter from the manufacturer, specify Model 59095-1, Catalog No. A-8078-L.

COUNTER INSTALLATION

The counter may be attached to the machine at any location that will not interfere with the machine operation. Connect an air line between the counter and port 5 on power valve P1. Refer to Paragraph 2.2, Functional Description, and to pneumatic drawing 854258.